

Spring Latches

Steel / Stainless Steel, for Welding

SPECIFICATION

Types

- Type **A**: Square, latch riveted, not removable
- Type **AU**: Square, latch screwed, removable
- Type **R**: Round, latch riveted, not removable
- Type **RU**: Round, latch screwed, removable

Guide

- Steel precision casting **ST**
Weldable
Blackened
- Stainless steel precision casting AISI 316 **A4**
Weldable

Latch

- Steel precision casting
Zinc plated, blue passivated (for ST)
- Stainless steel precision casting AISI 316 (for A4)

Plunger pin

- Steel, zinc plated, blue passivated (for ST)
- Pressure spring
Stainless steel AISI 316 (for A4)

Pressure spring

Stainless steel AISI 316Ti

Countersunk screw

- Steel, zinc plated (for ST)
- Stainless steel (for A4)

INFORMATION

With spring latches GN 722.1, the plunger pin is retracted over the curve of the guide by a 180° turn of the latch. The notch at the upper end of the curve causes the latch to be held in place if the plunger pin needs to be kept temporarily from protruding. The **ST** version is designed for applications in steel construction, whereas the stainless steel version **A4** is suitable for use in particularly aggressive environments.

The dimensional tolerances between plunger pin and guide are selected so that the functional reliability is guaranteed even after welding, applying a corrosion protection layer or in case of contamination.

For fastening by welding, the unmounted type AU is particularly recommended to avoid changes to the microstructure of the material due to heating of the spring and plunger pin. In this case, the indexing plunger is assembled only after the surface treatment of the welded guide.

- List of Cam Action Indexing Plungers (see page 816)

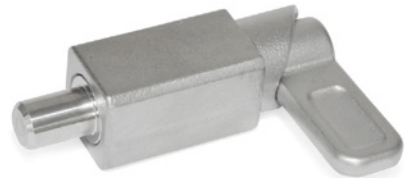

TECHNICAL INFORMATION

- Load Rating Information (see page A42)
- Stainless Steel Characteristics (see page A26)

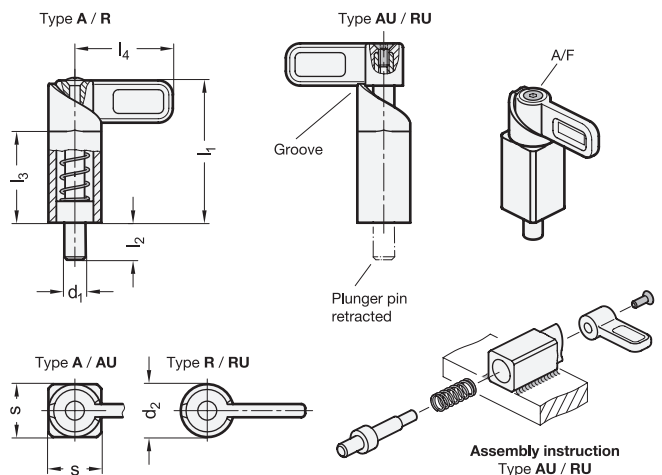

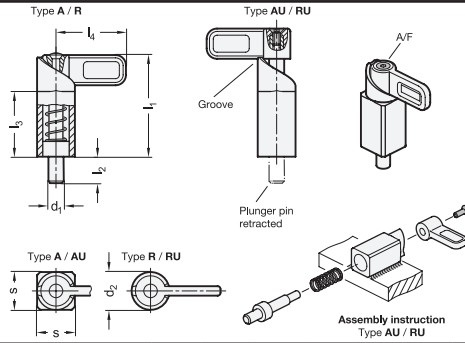

GN 722.1-ST

Description	d1 Pin -0.05/-0.25 Bore +0.1/+0.3	d1 Pin -0.05/-0.25 Bore +0.2/+0.4	s	d2	l1 ≈	l2	l3	l4	A/F	Spring load in N≈ initial	Spring load in N≈ end	⚖️
GN 722.1-8-20-A-ST	8	-	20	-	54	14	35	37	2.5	14	35	135
GN 722.1-10-20-A-ST	10	-	20	-	54	14	35	37	2.5	14	35	144
GN 722.1-12-20-A-ST	12	-	20	-	54	14	35	37	2.5	14	35	148
GN 722.1-14-20-A-ST	14	-	20	-	54	14	35	37	2.5	14	35	153
GN 722.1-16-30-A-ST	16	-	30	-	83	20	54	55	4	22	70	622
GN 722.1-20-30-A-ST	20	-	30	-	83	20	54	55	4	22	70	639
GN 722.1-8-20-AU-ST	8	-	20	-	54	14	35	37	2.5	14	35	135
GN 722.1-10-20-AU-ST	10	-	20	-	54	14	35	37	2.5	14	35	144
GN 722.1-12-20-AU-ST	12	-	20	-	54	14	35	37	2.5	14	35	148
GN 722.1-14-20-AU-ST	14	-	20	-	54	14	35	37	2.5	14	35	153
GN 722.1-16-30-AU-ST	16	-	30	-	83	20	54	55	4	22	70	622
GN 722.1-20-30-AU-ST	20	-	30	-	83	20	54	55	4	22	70	639
GN 722.1-8-20-R-ST	-	8	-	20	54	14	35	37	-	14	35	117
GN 722.1-10-20-R-ST	-	10	-	20	54	14	35	37	-	14	35	120
GN 722.1-12-20-R-ST	-	12	-	20	54	14	35	37	-	14	35	124
GN 722.1-14-20-R-ST	-	14	-	20	54	14	35	37	-	14	35	129
GN 722.1-16-30-R-ST	-	16	-	30	83	20	54	55	-	22	70	431
GN 722.1-20-30-R-ST	-	20	-	30	83	20	54	55	-	22	70	449
GN 722.1-8-20-RU-ST	-	8	-	20	54	14	35	37	-	14	35	117
GN 722.1-10-20-RU-ST	-	10	-	20	54	14	35	37	-	14	35	120
GN 722.1-12-20-RU-ST	-	12	-	20	54	14	35	37	-	14	35	124
GN 722.1-14-20-RU-ST	-	14	-	20	54	14	35	37	-	14	35	128
GN 722.1-16-30-RU-ST	-	16	-	30	83	20	54	55	-	22	70	431
GN 722.1-20-30-RU-ST	-	20	-	30	83	20	54	55	-	22	70	449

GN 722.1-A4

STAINLESS STEEL

Description	d1 Pin -0.05/-0.25 Bore +0.1/+0.3	d1 Pin -0.05/-0.25 Bore +0.2/+0.4	s	d2	l1 ≈	l2	l3	l4	A/F	Spring load in N≈ initial	Spring load in N≈ end	⚖️
GN 722.1-8-20-A-A4	8	-	20	-	54	14	35	37	2.5	14	35	142
GN 722.1-10-20-A-A4	10	-	20	-	54	14	35	37	2.5	14	35	146
GN 722.1-12-20-A-A4	12	-	20	-	54	14	35	37	2.5	14	35	148
GN 722.1-14-20-A-A4	14	-	20	-	54	14	35	37	2.5	14	35	150
GN 722.1-16-30-A-A4	16	-	30	-	83	20	54	55	4	22	70	612
GN 722.1-20-30-A-A4	20	-	30	-	83	20	54	55	4	22	70	643
GN 722.1-8-20-AU-A4	8	-	20	-	54	14	35	37	2.5	14	35	142
GN 722.1-10-20-AU-A4	10	-	20	-	54	14	35	37	2.5	14	35	146
GN 722.1-12-20-AU-A4	12	-	20	-	54	14	35	37	2.5	14	35	148
GN 722.1-14-20-AU-A4	14	-	20	-	54	14	35	37	2.5	14	35	150
GN 722.1-16-30-AU-A4	16	-	30	-	83	20	54	55	4	22	70	612
GN 722.1-20-30-AU-A4	20	-	30	-	83	20	54	55	4	22	70	643
GN 722.1-8-20-R-A4	-	8	-	20	54	14	35	37	-	14	35	121
GN 722.1-10-20-R-A4	-	10	-	20	54	14	35	37	-	14	35	123
GN 722.1-12-20-R-A4	-	12	-	20	54	14	35	37	-	14	35	125
GN 722.1-14-20-R-A4	-	14	-	20	54	14	35	37	-	14	35	129
GN 722.1-16-30-R-A4	-	16	-	30	83	20	54	55	-	22	70	433
GN 722.1-20-30-R-A4	-	20	-	30	83	20	54	55	-	22	70	452
GN 722.1-8-20-RU-A4	-	8	-	20	54	14	35	37	-	14	35	121
GN 722.1-10-20-RU-A4	-	10	-	20	54	14	35	37	-	14	35	123
GN 722.1-12-20-RU-A4	-	12	-	20	54	14	35	37	-	14	35	125
GN 722.1-14-20-RU-A4	-	14	-	20	54	14	35	37	-	14	35	129
GN 722.1-16-30-RU-A4	-	16	-	30	83	20	54	55	-	22	70	433
GN 722.1-20-30-RU-A4	-	20	-	30	83	20	54	55	-	22	70	452

