

Breather caps

Technopolymer, high filtration, with double valve, splash guard, and flat dipstick

COVER

Polyamide-based (PA) technopolymer, black colour RAL 9005, matte finish, laser engraved graphic symbols.

THREADED FITTING

Polyamide-based (PA) technopolymer, with splash guard and hexagon nut, black colour, semi-matte finish.

PACKING RING

NBR synthetic rubber flat washer.

OVERPRESSURE VALVE

Technopolymer with NBR synthetic rubber O-ring. Stainless steel spring, set at around 0.350 bar.

SUCTION VALVE

NBR synthetic rubber and stainless steel spring. Set at around 0.030 bar.

AIR FILTER

Polyester with a filtration rate of $3\mu\text{m}$ (efficiency > 98%).

FLAT DIPSTICK

Flat section phosphated steel (maximum visibility of the fluid level). On request and for sufficient quantities dipstick can be supplied in different lengths and/or complete with MAX-MIN level lines.

MAXIMUM CONTINUOUS WORKING TEMPERATURE

100°C.

FEATURES

The SFW-AF (registered design) breather cap maintains a reservoir of air under pressure above the oil level within the limits established in the design stage to avoid deformation of the tank walls. Benefits:

- it reduces reservoir air volume intake keeping clean oil and filter;
- it improves suction pump action under working conditions reducing cavitation phenomenon;
- it prevents fluid leakage when the system is part of a mobile unit;
- it reduces foam in fluid.

SFW-AF caps are made with a special internal geometry which stops the leakage of the fluid to the outside.

The hexagon on the threaded fitting makes it possible to apply, using a wrench, a greater tightening torque on the cap, ensuring better compression of the gasket.

TECHNICAL DATA

Air flow rate for the different executions of breather caps can be obtained from the diagram on the basis of the difference of air pressure inside and outside the reservoir.

SPECIAL EXECUTIONS ON REQUEST

- Black cover without graphic symbol.
- Orange cover.
- Orange cover without graphic symbol.
- Yellow cover.
- Yellow cover without graphic symbol.
- Dipstick can be supplied in different lengths and/or complete with MAX-MIN level lines.



ELESA Original design

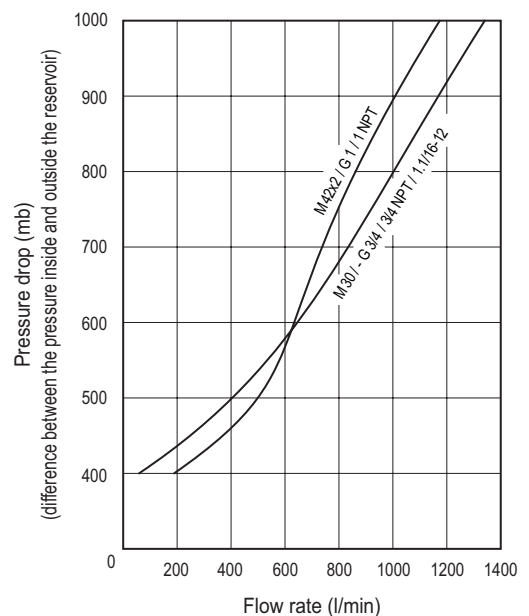
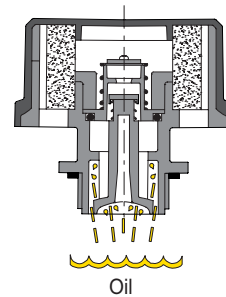

SFW-AF pressurised breather cap functioning in a hydraulic circuit

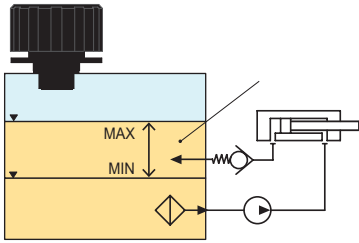

Normal working conditions

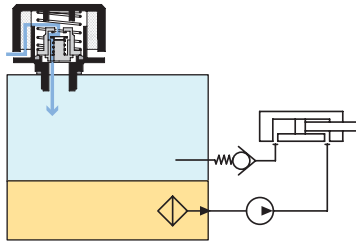

When in the reservoir a depression around 0.030 bar is produced, a flux of air entering the reservoir through the suction valve takes place.

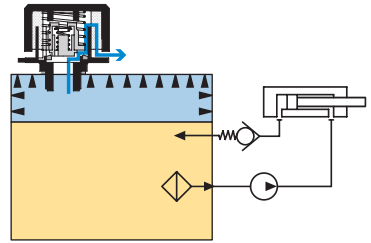

When in the reservoir an over pressure exceeding 0.350 (or 0.700) bar is produced, a flux of air is discharged through the safety valve.

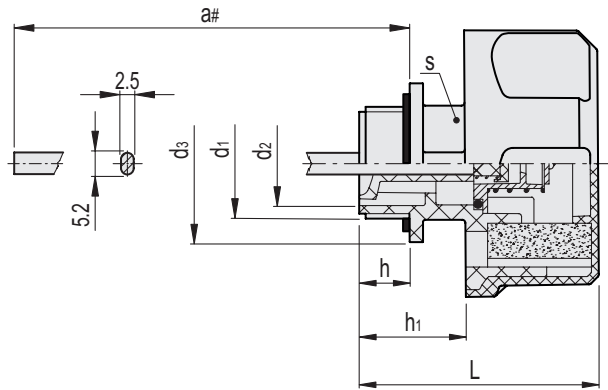
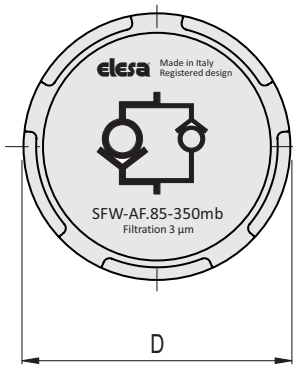

Code	Description	D	a#	L	d1	d2	d3	h	h1	s	⚖
52950-C9	SFW-AF.85-M30x1.5+FC3-350MB+a-C9	85	193	73	M30x1.5	23	38	16	30.5	28	156
52952-C9	SFW-AF.85-M42x2+FC3-350MB+a-C9	85	190	76	M42x2	33	50	16.5	34	36	165
52954-C9	SFW-AF.85-G3/4+FC3-350MB+a-C9	85	193	73	G 3/4	20.5	35	16	30.5	28	155
52956-C9	SFW-AF.85-G1+FC3-350MB+a-C9	85	193	73	G1	25	40	16	30.5	28	158
952956-C9	SFW-AF.85-1 NPT+FC3-350MB+a-C9	85	193	73	3/4 NPT	20.5	36	16.5	30.5	28	155
952954-C9	SFW-AF.85-3/4 NPT+FC3-350MB+a-C9	85	191	77	1 NPT	27	41	19	34.5	34	158
952958-C9	SFW-AF.85-1.1/16-12 SAE+FC3-350MB+a-C9	85	193	73	1.1/16-12 UNF	20.5	35	16	30.5	28	154

